

ETS

IP65 Twinspot

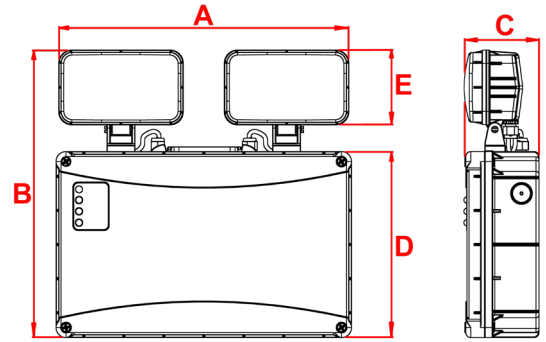

2x221 Lumens	2 x 2.5 Watts	6500K	Wall Mounting
Ni-Cd Battery	Class II	IP 65	4Y Warranty

Materials

Housing: Polycarbonate
Standard Colour: White - RAL 9016

Warranty

Standard Warranty: 4 Years
Alternative Warranty: 8 Years
Add /8Y to Order Code

Order Code	ETSLED/NM3/IP65
Mode of operation	Non-Maintained
Emergency duration	3 hours
Input voltage	230/240V (207VAC - 264VAC) 50/60Hz
Power consumption	4VA, I _{nom} = 17mA (Full Battery)
Battery type	Rechargeable NiCd 3.6V, 6Ah
Battery low voltage cut off	3.2V DC
Battery discharge current @ 3.6V DC	1.2A
Lamp	2 X 2.5W LED
Lamp colour	6500K
Lumen Level in Emergency	2 X 221lm
Nominal lamp voltage	V _{rated} = 3.3V DC
Nominal lamp current @ 3.6V	I _{rated} = 0.6A CC
Nominal lamp power @ 3.6V	P _{rated} = 2W (Per Lamp)
Maximum output voltage with no lamp connected	U-OUT = 4.1V DC
Ingress protection	IP65
Cable entry	20mm on sides and Top of product
Luminaire class	Class II
Product Weight	1.6 Kg
Packaging Weight	0.14 Kg
Standards	EN61347-2-7, EN61347-2-13, EN 60598-2-22, EN 55015
Environment	0°C to 45°C up to 80% relative humidity

System	Order Code	Mode of Operation	Battery	Battery P/N	Lumens (Emergency)	Dimensions (mm)				
						A	B	C	D	E
Standalone	ETSLED/NM3/IP65	Non-Maintained	3.6V, 6Ah Ni-Cd	70147	2 x 221	296	287	73	185	74